

# Strength and resistance of nailed plywood joints for Canada Plan Service trusses

D. I. MASSÉ<sup>1</sup>, J. J. SALINAS<sup>2</sup>, and J. E. TURNBULL<sup>1</sup>

<sup>1</sup>Engineering and Statistical Research Centre, Research Branch, Agriculture Canada, Ottawa, Ontario K1A 0C6; and  
<sup>2</sup>Department of Civil Engineering, Carleton University, Ottawa, Ontario K1S 5B6. Contribution no. 1-846<sup>1</sup>, received 28 August 1986, accepted 8 March 1988.

Massé, D. I., J. J. Salinas, and J. E. Turnbull. 1988. **Strength and resistance of nailed plywood joints for Canada Plan Service trusses.** Can. Agric. Eng. 30: 283-287. A preliminary study was made to find a replacement for 12.5-mm, 5-ply Douglas fir plywood, previously used for gussets in Canada Plan Service trusses, and now in short supply. The proposed alternative, 18.5-mm, 5-ply Douglas fir plywood, requires larger 4.5 × 76-mm concrete nails to maintain full double-shear. This study evaluated the load-deformation behavior of these connections and assessed the effects of nailing patterns. Results indicated that the proposed alternative better matched the strength of the sawn lumber frame members. Results also indicated that a 4.5 × 76-mm concrete nail had a mean safe working load of 1.25 kN (working stress design method), corresponding to a unit lateral resistance of 2.14 kN (limit states design method). These values were for joints using 14 nails and were 8% lower than for joints using four nails.

## INTRODUCTION

Nailed plywood gusset connections can be used to join the in-plane members of farm building roof trusses. Bottom chord tension splices often constitute the weak link in the assembly and influence the overall design for a given truss (Massé 1985). The gable and gambrel roof truss series of the Canada Plan Service (CPS) have used this type of connection since 1962. A typical bottom chord splice consisted of two pieces of 38-mm S-P-F No. 2 sawn lumber butt-jointed with pairs of 12.5-mm, 5-ply Douglas fir exterior sheathing plywood side plates nailed from both sides with 4 × 64-mm spiral concrete nails driven by hand (Fig. 1).

The 12.5-mm, 5-ply (12.5/5) plywood specified for the side plates has been phased out of the Canadian market and is being replaced with 12.5-mm, 4-ply (12.5/4). It is now extremely difficult to obtain the 5-ply material, necessitating consideration of an alternative splicing material. One obvious alternative would be the 4-ply material. In addition, 18.5-mm plywood could be considered, including 5-, 6- and 7-ply. Thicker plates would require longer nails which have larger diameters and exhibit different behavior characteristics.

A theoretical study and test program were required to determine the best alternative to splice the CPS trusses. The work reported here determined the nail lateral resistance for the different splicing alternatives and how it was affected by the number of rows of nails. Finally, design values for the nail lateral resistance for the most appropriate splicing alternative were derived for both the working stress and limit states design methods.

## PRELIMINARY FINDINGS

It was possible to perform some preliminary calculations to

clarify and define the scope of this investigation. These calculations were based on an assumed control specimen and its strength characteristics, as defined by Engineering Design in Wood (Limit States Design) CAN3-086.1-M84 (CSA, 1984b Canadian Standards Association), hereafter called the "LSD wood code".

The strength of a tension splice may be governed by:

- The strength of the lumber members being spliced.
- The strength of the plywood side plates.
- The strength of the wood-nail-wood connection.

In order to evaluate and compare the various alternatives it was assumed that the splice would join two pieces of lumber, S-P-F, No. 2, 38 × 184 mm. Furthermore, it was assumed that a sufficient number of nails would be used such that the strength of the joint would be governed either by the strength of the lumber or the plywood.

According to the LSD wood code, the factored tensile resistance parallel-to-grain of sawn lumber is given by:

$$T_r = \emptyset F_t A_n (K_d K_{st} K_t K_z K_e) K_h \quad (1)$$

$$= 46\,300 \text{ N}$$

where:

- $\emptyset$  = 0.7 (resistance factor);
- $F_t$  = 8.6 MPa (specified strength in tension, Table 50, p. 190);
- $A_n$  = 38 × 184 = 6992 mm<sup>2</sup> (area of sawn lumber);
- $K_d$  = 1.00 (load duration factor);
- $K'_{st}$  = 1.00 (dry service conditions);
- $K_t$  = 1.00 (no pressure treatment);
- $K_z$  = 1.10 (size factor, Table 12, p. 76);
- $K_e$  = 1.00 (specific grade factor, Table 13, p. 77);
- $K_h$  = 1.00 (no load sharing).

According to the LSD wood code the factored tensile resistance parallel to a face grain edge for Douglas fir plywood is given by:

$$T_r = \emptyset T_p b_n (K_d K'_{st} K_t) X_j \quad (2)$$

$$= 257.6 T_p$$

where:

- $\emptyset$  = 0.7 (resistance factor);
- $T_p$  = tensile strength parallel-to-face grain (Table 56, p. 199); depends on plywood thickness;
- $b_n$  = 184-mm × 2 side plates = 368 mm;
- $K_d$  = 1.00 (load duration factor);
- $K'_{st}$  = 1.00 (dry service conditions);

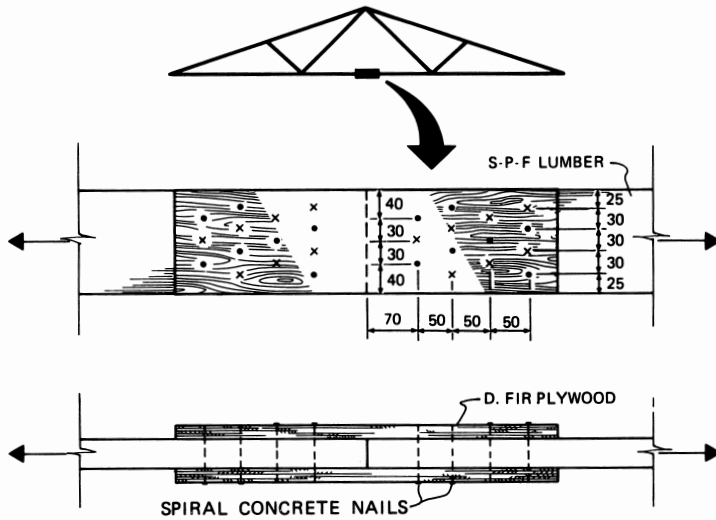

Figure 1. Typical tension splice.

$$K_t = 1.00 \text{ (no pressure treatment);}$$

$$X_j = 1.00 \text{ (stress joint factor).}$$

Calculations were carried out to compare five designs using various plywood thicknesses and ply combinations (Table I). Using 12.5-mm plywood and going from 5-ply to 4-ply, the factored tensile strength of the plywood drops from 41.2 kN to 30.9 kN, a 25% loss in strength.

Furthermore, the plywood/lumber strength ratios for 4-ply and 5-ply plywood are only 0.62 and 0.89, respectively. This indicates inefficient use of lumber in either case since its tensile strength is not fully utilized.

A plywood thickness of 18.5 mm with 5, 6 or 7 plies was considered next (Table I). The 18.5/5 alternative has a potential tensile strength of 46.4 kN, and is capable of fully utilizing the potential tensile strength of the lumber, as it provides a strength ratio = 1.00.

From this preliminary comparison it was determined that the 18.5/5 alternative would be the most viable replacement for the 12.5/5. Furthermore, Table I shows that the 18.5-mm plywoods with 6 and 7 plies provide an even greater strength ratio (1.17), so that inadvertent substitution of these alternative plywoods will not compromise the safety of a design. However, the thicker plywood requires longer, bigger nails which need further study to evaluate their performance.

### TEST PLAN

The behavior of nailed joints is affected by many factors, some of them beyond the exploratory nature of this investigation. The

Table I. Actual and relative tensile strengths of plywood gussets and lumber truss frames

Plywood		Component tensile strength† (kN)		Strength ratio plywood/lumber
Nominal thickness (mm)	Number of plies	Plywood	Lumber	
12.5	4	30.9	46.3	0.67
12.5	5	41.2	46.3	0.89
18.5	5	46.4	46.3	1.00
18.5	6	54.1	46.3	1.17
18.5	7	54.1	46.3	1.17

†From eq. 2 for plywood; eq. 1 for lumber.

main parameters to be considered were the plywood thickness and number of plies (12.5/4, 12.5/5, 18.5/5). Plywood thickness has an obvious effect on nail size (length and therefore diameter). Two sizes of Canadian concrete nails were considered: 4 × 64 mm and 4.5 × 76 mm.

Recent research on the behavior of groups of nails (Malhotra and Thomas 1984) indicates the need to consider the effects of nailing patterns (number of rows) on the strength and deformation behavior of nailed joints. The effects of other factors such as moisture content, specific gravity, modulus of elasticity and modulus of rupture for the wood components were controlled to minimize variations from these sources.

The research effort was focussed on the nail behavior in splices under tension to determine:

- (1) Nail lateral resistance for three plywood alternatives (12.5/4, 12.5/5 and 18.5/5).
- (2) Effect of nailing pattern (number of rows) for the proposed plywood alternative (18.5/5).

### Experiment design

To achieve the proposed goals, 48 specimens were fabricated and grouped into four series as shown in Table II. Series 1 and 2 were intended to study the behavior and strength of joints with 12.5/4 and 12.5/5 plywood, respectively. Series 3 was perhaps the most important since the results from this series were used to calculate design values for nail capacity. These three series were then used to characterize nail lateral resistance for various plywood configurations. Results from Series 4, with only one row of nails, were compared with those from Series 3 (four rows) to study the effect of nailing pattern.

### Test specimens

Figure 2 shows the joint geometry and nailing patterns used for Series 1 through 3. For all series, the main members were cut from green 38 × 140-mm, No. 2 S-P-F lumber, 2400 mm long. In order to obtain enough material for two specimens from each board, the sawn lumber was cut into 600-mm lengths. Side plates were cut from 1220 × 2440-mm Douglas fir exterior sheathing plywood so the face grain was parallel to the main members. Concrete spiral nails were used — 64-mm × 4-mm diameter for the 12.5/4 and 12.5/5 side plates, and 76-mm × 4.5-mm diameter for the 18.5/5 side plates. Nails were driven from both sides completely penetrating all three members. The nail heads were driven flush with the surface of the plywood.

### Specimen conditioning

The moisture content for the S-P-F No. 2 lumber was in excess of 30% at the time of fabrication. Immediately after fabrication the specimens were stored for 2 mo in a conditioning room at 20°C and 80% relative humidity, which corresponds to a wood equilibrium moisture content of 16%. Actual moisture content of the conditioned specimens ranged from 15 to 17%.

Drying shrinkage introduces a gap between the plywood side plates and the main lumber members. This reduces friction between gussets and main members giving a more realistic nail performance at small joint displacements. This procedure also removes the need to consider the  $K_{sf}$  factor of 0.80 specified in the LSD wood code, Table 21, for nailed joints assembled "wet" and laterally loaded "dry", and is similar to typical on-site farm building construction practice in most of Canada.

### TEST PROCEDURE

All tests were carried out at the Structures Laboratory, Depart-

**Table II. Test parameters**

Series	Plywood			Nails			Rate of loading (KN/min)
	Nominal thickness (mm)	No. of plies	Number	Diam. (mm)	Length (mm)	No. of rows	
1	12.5	4	14	4.0	64	4	4.45
2	12.5	5	14	4.0	64	4	4.45
3	18.5	5	14	4.5	76	4	4.45
4	18.5	5	4	4.5	76	1	4.45

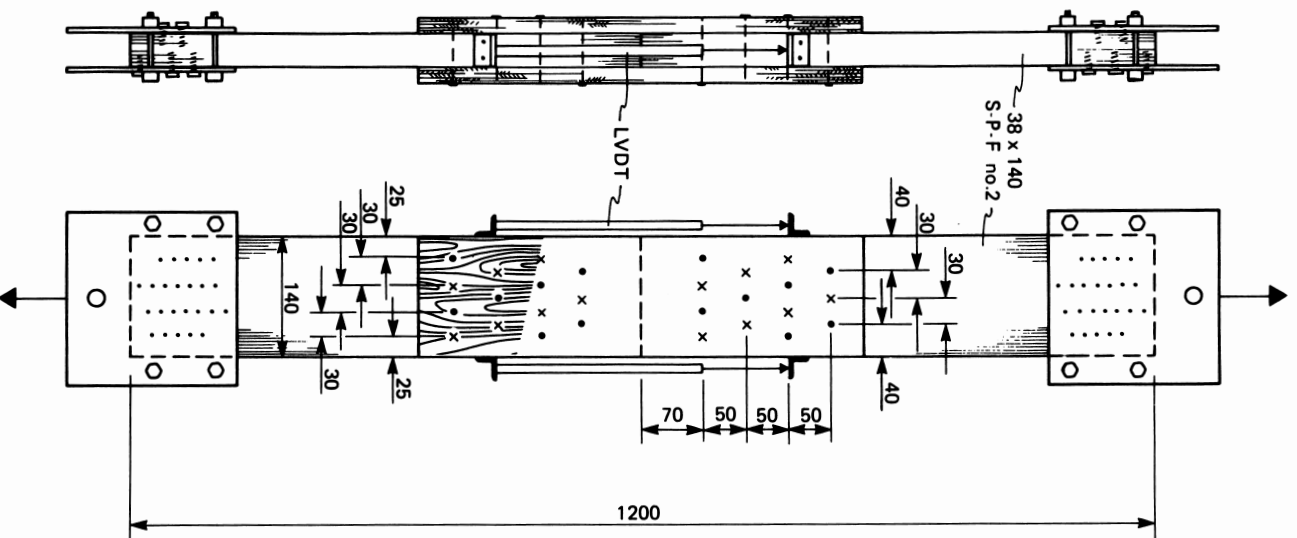
**Figure 2.** Details of specimen and test fixtures.

ment of Civil Engineering, Carleton University, Ottawa, Ontario. Specimens consisting of two double-shear joints in series (Fig. 2) were tested at random in a Tinius-Olsen 1.8 MN universal testing machine at a loading rate of 4.5 kN/min. Joint slip was measured using the average reading from two displacement transducers (LVDT), one on each side of the joint. Using

Series	At slip of:			At failure
	0.4 mm	1.27 mm	6.4 mm	
1	746 (0.076)	1540 (0.054)	3229 (0.033)	3656 (0.048)
2	798 (0.073)	1625 (0.053)	3266 (0.050)	3912 (0.067)
3	1028 (0.058)	2140 (0.040)	4407 (0.040)	5300 (0.070)
4	1106 (0.075)	2312 (0.063)	4598 (0.064)	5737 (0.070)

†Nail capacity reported here corresponds to the mean value obtained from a sample size of 12 specimens. Numbers in parentheses are the corresponding coefficients of variation.

an X-Y plotter, a continuous load-slip curve was recorded up to a two-joints-in-series displacement of 12.8 mm. Beyond this displacement the plotter was disconnected and only the failure load was recorded.

## RESULTS AND DISCUSSION

### Load-slip results

From the load-slip curve recorded during each test, loads were read for single-joint displacements of 0.4 mm, 1.27 mm, 6.4 mm, as well as at failure. The load for each slip was then averaged over the 12 specimens for each series and divided by the corresponding number of nails (Table III). The mean values reported in Table III have been plotted in Fig. 3 to show the general trend of the load-slip relationship for Series 1 through 4.

Individual load-slip relationships recorded for each test show a markedly nonlinear behavior of the nailed connections for all series at all load levels. This trend is also noticed in the mean-value curves shown in Fig. 3.

### Plywood alternatives

Curves marked S1, S2 and S3 in Fig. 3 show the mean nail capacity of Series 1, 2 and 3, corresponding to plywood alternatives 12.5/4, 12.5/5, 18.5/5, respectively. Nail capacity for alternative 12.5/4 (S1) is slightly below alternative 12.5/5 (S2) and thus would not be a very desirable replacement. This agrees with other findings (Turnbull and Lefkovich 1985). On the other hand, nail capacity for alternative 18.5/5 (S3) is clearly superior to the preceding two. According to Table III, the mean lateral nail capacity for 18.5-mm 5-ply (Series 3), at a displacement of 1.27 mm, is 1.38 and 1.31 times those with 12.5-mm 4-ply and 12.5-mm 5-ply (Series 1 and 2), respectively. Consequently, if the 18.5/5 plywood alternative was adopted as a replacement for the 12.5/4, the joint would require 38% fewer nails and shorter side plates. This is a clear advantage over both the 12.5/4 and 12.5/5 alternatives.

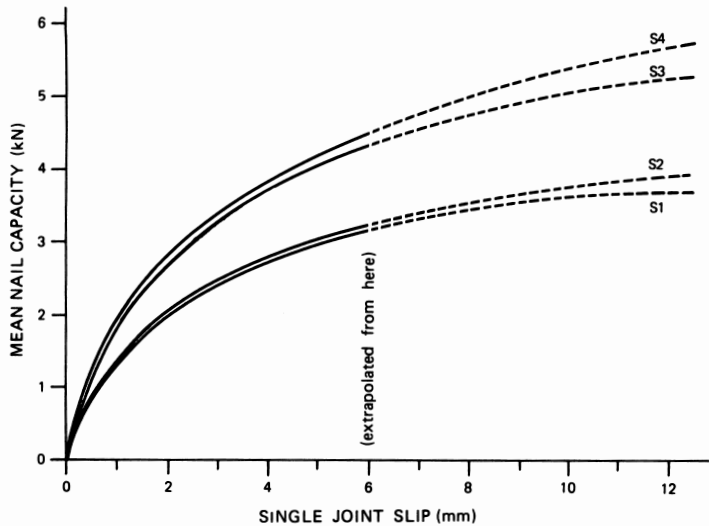

Figure 3. Load-slip curves for nailed connections. Load corresponds to mean value of nail capacity. Slip corresponds to one-half of the overall joint displacement. Curves S1 through S5 correspond to Series 1 through 5, respectively.

### Number of rows of nails

In order to determine the effect of number of rows of nails, the results of Series 3 (4 rows) and Series 4 (1 row) must be examined. From Fig. 3 and Table III it can be observed that Series 4 (1 row) shows higher strength per nail at all load levels. Statistical analysis showed that the results from Series 3 and 4 are significantly different. This means that when the number of rows increases from 1 to 4 the reduction in nail capacity is in the order of 8%. This is in agreement with Malhotra and Thomas (1984).

### Failure modes

Three basic failure modes were observed in these tests:

- (1) Gusset (plywood) failure.
- (2) Main member (lumber) failure.
- (3) Nail head pulled through side plates.

Table IV shows the fraction of all test specimens which failed under each mode for Series 1, 2 and 3. Series 1 specimens (12.5/4 plywood) failed predominantly in plywood tension. This was expected because this plywood has the lowest tensile strength. All specimens in Series 2, with the smaller nails and stronger plywood (12.5/5) experienced a mode 3 failure. Series 3 using the longer nails (4.5 × 76 mm) and stronger plywood (18.5/5) had a more balanced distribution of failures of mode 2 and mode 3.

### NAIL CAPACITY DESIGN VALUES

The most promising alternative for nailed gusset splices is the 18.5-mm, 5-ply plywood. It requires 4.5-mm-diameter, 76-mm-long, spiral concrete nails. No design values are given

Table IV. Fraction of all test specimens failing at each mode

Series	Mode 1†	Mode 2†	Mode 3†
1	7/12	0	5/12
2	0	0	12/12
3	2/12	5/12	5/12

†Mode 1, plywood failure; Mode 2, lumber failure; Mode 3, nail pull-through.

for this combination of materials by the code or elsewhere in the literature.

For the design of low-human-occupancy buildings using the Working Stress Design methods, Massé and Turnbull (1986) recommended a design capacity of 1.25 kN per nail for the alternative proposed here. This capacity is based on the near minimum (5th percentile) nail capacity at 1.27 mm slip, corrected to "normal" load duration by dividing by a factor of 1.6.

Massé and Turnbull (1986) assumed a ratio of 1.714 between Limit States Design (strength) nail capacity values and those for Working Stress Design. Therefore, in a LSD (strength) design environment, Massé and Turnbull (1986) recommended a unit lateral resistance of  $1.71 \times 1.25 \text{ kN} = 2.14 \text{ kN}$ , for low-human-occupancy buildings as defined in the Canadian Farm Building Code (Task Group on Farm Buildings 1983).

Larsen (1973) reported a theoretical approach to the determination of the lateral load capacity of bolted connections based on the bolt diameter, relative sizes of the main member and the side members, embedding strength of the wood and the bolt yielding moment.

This approach has been extended to nailed connections to determine nail capacity values for the ultimate strength limit state in the LSD wood code. Five different failure modes are considered: (a) side member failure, (b) main member failure, (c) side member failure and nail yielding in main member, (d) main member failure and nail yielding in side member, (e) nail yielding in main member and in side members. Each failure mode is characterized by a theoretical expression used to calculate the failure load. The failure mode which results in the lowest ultimate load controls the design for the connection. The proposed alternative was studied using these five equations and the controlling mode was found to be main member failure, at a load of 1.65 kN. For use in buildings with low human occupancy this value could be upgraded to  $1.25 \times (1.65 \text{ kN}) = 2.06 \text{ kN}$  which agrees closely, being only 4% smaller than the proposed value of 2.14 kN.

### WORK BY OTHER RESEARCHERS

A literature review on the lateral resistance of nailed connections has already been published (Massé 1985).

Turnbull and Lefkovich (1985) tested nailed joints using S-P-F No. 2 lumber, 12.5/5 and 12.5/4 Douglas fir plywood and 4 × 64-mm spiral nails. The ramp load applied was designed to produce failure in 25 min.

The results are shown in Table V and should be compared with those obtained for Series 1 and 2 in this investigation. At a slip of 0.4 mm, their results for 12.5/4 and 12.5/5 plywood were 30 and 20% lower than those found for Series 1 and 2, respectively. The difference between the two studies becomes much smaller at larger slips. For slips of 1.27 mm and 6.4 mm, for example, the difference is less than 10%. The large differences found at low slips were probably due to the different testing methods. Turnbull and Lefkovich (1985) used the A-frame system shown in Fig. 4. Displacements were measured at the crown, at the point of application and in the direction of the load. Corrections were then applied to account for the truss geometry and the elastic deformation of lumber and plywood. Given the nature of the load-slip curve at small deformations, a small error in the corrections could induce larger errors in determining the lateral nail resistance. This effect would be attenuated at larger deformations. For example, at a slip of

**Table V. Nail capacity (N) from previous test reports**

Test	At slip of:		
	0.44 mm	1.27 mm	6.4 mm
(A)†	520	1528	3270
(B)†	640	1579	3610

(A) Tests on 12.5/4 plywood. Similar to Series 1 of this study. (B) Tests on 12.5/5 plywood. Similar to Series 2 of this study. (Source: Turnbull and Lefkovitch 1985.)

1.27 mm, the difference is under 3%, showing good agreement between these two studies.

Malhotra and Thomas (1984) investigated the effect of nailing patterns (number of rows) on the lateral resistance of nails, using lap joints of solid lumber members in tension. The 3.25-mm-diameter nails were driven into 2.38-mm predrilled holes (73% of the nail diameter). Nail heads were not driven flush with the surface of the side member. Lower values are reported for the lateral resistance per nail in joints with four rows of one nail than that found in joints with a single nail. At a joint slip of 0.4 mm the decrease in nail lateral resistance was 7% for specimens with a 0.53-mm gap and 11% for specimens with a 1.19-mm gap.

For Series 3 and 4 of this study, the average gap size due to shrinkage and/or fabrication error was 0.47 mm, with a coefficient of variation of 1.05. Therefore, the 8% difference between Series 3 and 4 found in this investigation is in good agreement with that reported by Malhotra and Thomas (1984).

### CONCLUSIONS

(1) The 18.5-mm 5-ply exterior sheathing Douglas fir plywood option provides a splice that best matches the strength of the sawn lumber and is recommended for use in Canada Plan Service trusses.

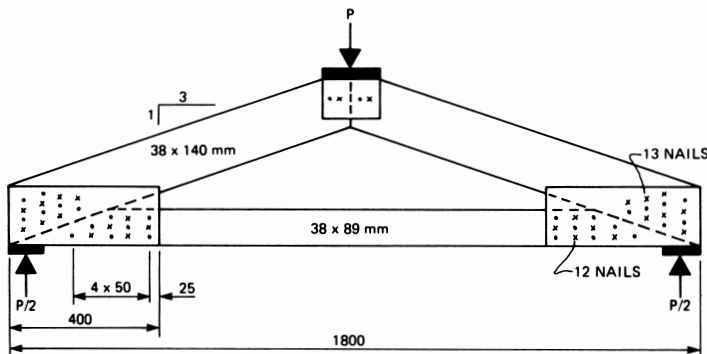

Figure 4. Testing method used by Turnbull and Lefkovitch (1985).

(2) Nailing patterns had an effect on the lateral resistance of 4.5 x 76-mm spiral concrete nails. More realistic design values are obtained from tests using several rows of nails.

(3) For the joint arrangement considered in this study, a safe working load of 1.25 kN per nail is recommended for use in Working Stress Design for buildings with low human occupancy. This represents the lower 5th percentile value at 1.27 mm slip divided by 1.6 to adjust to "normal" load duration.

(4) For the joint arrangement considered in this study, a unit lateral resistance of 2.14 kN per nail is recommended for use in Limit States Design for buildings with low human occupancy.

(5) Good agreement was found between the experimental results reported by other researchers and those found in this study. Further work is needed to quantify the duration of load effect.

### ACKNOWLEDGMENT

The authors would like to express their appreciation to the Department of Civil Engineering, Carleton University, Ottawa, Ontario for providing access to the Structures Laboratory where most of the tests were performed.

### REFERENCES

- LARSEN, H. J. 1973. The yield load of bolted and nailed joints. Proceedings International Union of Forestry Research Organization Meeting, Johannesburg, South Africa.
- MASSE, D. I. 1985. Design and analysis of multi-laminated nailed joint trusses. M. Eng. Thesis. Dept. of Civil Engineering, Carleton University, Ottawa, Ontario. 154 pp.
- MASSE, D. I., and J. E. TURNBULL. 1986. Canada Plan Service truss design. Rept. I-804, Eng. & Stat. Res. Centre, Res. Br., Agric. Canada, Ottawa, Ontario. 15 pp.
- MALHOTRA, S. K. and B. THOMAS. 1984. Effect of interface gap on load-slip characteristics of timber joints fabricated with multiple nails. *Can. J. Civil Eng.* 12(1): 104-113.
- TASK GROUP ON FARM BUILDINGS. 1983. Canadian farm building code. NRCC no. 21312, National Research Council of Canada, Ottawa, Ontario.
- TURNBULL, J. E. and L. P. LEFKOVITCH. 1986. Nail loads for truss connections using steel vs. 5-ply and 4-ply fir and spruce plywood gussets. *Can. Agric. Eng.* 28:167-173.
- PALKA, L. C. 1985. Prediction of short- and long-term behavior of truss-plate joints in tension. Proc., International Workshop on Duration of Load in Lumber and Wood Products. Special publ. SP-27, Forintek Canada Corp., Vancouver, B.C., 51-60 pp.
- WOOD, L. W. 1951. Relation of strength of wood to duration of load. U.S. Forest Products Lab. Rep. No. 1916. USDA, Forest Service, Madison, Wis.